

DATE: _____

PROJECT: _____

LOCATION: _____



**Mixed Flow Inline
Horizontal
Belt Drive
Arrangement 9**

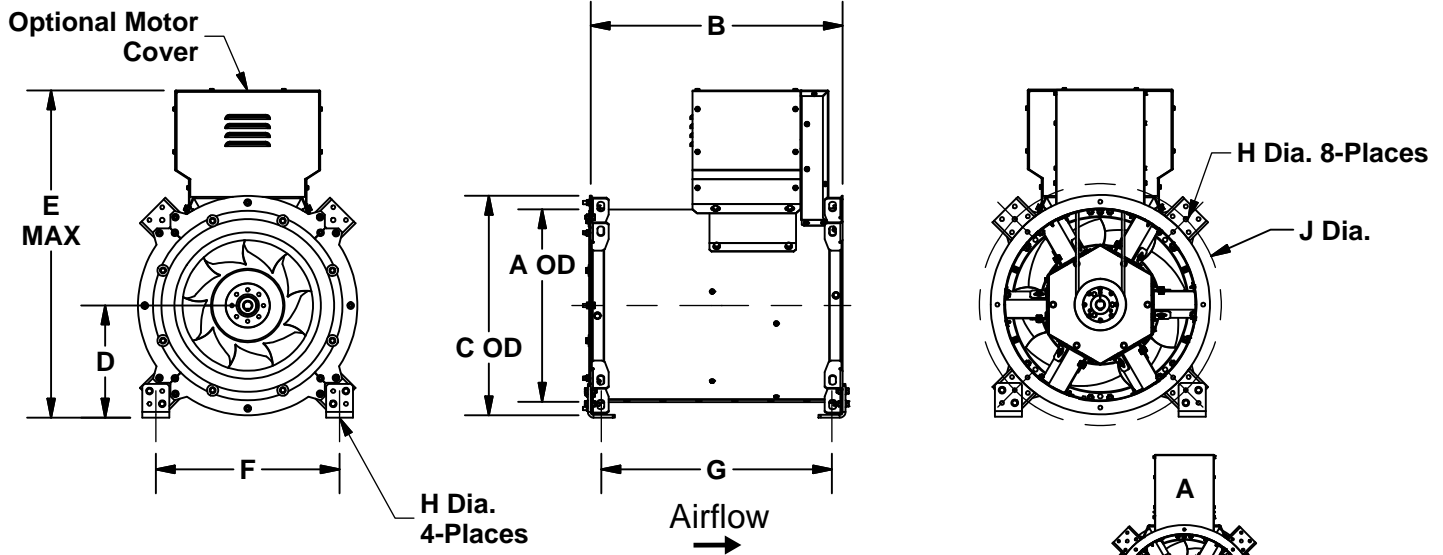

STANDARD CONSTRUCTION FEATURES:

High efficiency mixed flow wheel - Bolted galvanized steel housing and straightening vanes - Adjustable motor plate utilizing threaded studs for positive belt tensioning - Integrated lifting lugs - Ball bearings with extended lubrication lines - Belt guard - Bolted access door

**MOTOR POSITION CHART
(View Facing Outlet)**
Mounting positions are field adjustable

DIMENSION DATA

Size	A	B	C	D	E	F	G	H	J	Shaft Dia	Max Motor Frame	Unit Wt.
90	12 7/8	18 1/2	15 7/8	9 3/8	29 1/16	14 1/4	16 1/8	1/2	18 1/8	1	56	83
120	17 1/8	24 11/16	20 1/16	10 15/16	33 3/4	17 3/8	22 5/16	1/2	22 9/16	1	145T	117
135	19 3/16	27 3/4	22 1/4	11 11/16	35 1/2	18 15/16	25 3/8	1/2	24 3/4	1	145T	134
150	21 5/16	28	24 3/8	12 7/16	37 5/16	20 7/16	25 5/8	1/2	26 7/8	1	145T	148
165	23 7/16	30 13/16	26 1/2	13 9/16	39 1/2	22 1/8	28 7/16	1/2	29 1/4	1	145T	168
180	25 9/16	33 5/8	28 5/8	14 5/8	43 5/8	23 5/8	31 1/4	9/16	31 3/8	1	182T	192
202	28 11/16	37 11/16	31 3/4	16 1/8	46 11/16	25 13/16	35 5/16	9/16	34 1/2	1	184T	243
225	31 15/16	42	34 15/16	17 3/4	49 15/16	28 1/4	39 5/8	9/16	37 15/16	1	184T	283
245	34 3/4	44 1/2	38 3/4	21 7/16	57 1/16	31 5/8	42	11/16	42 3/4	1 3/16	213T	363
270	38 1/4	49 1/16	42 3/8	22 11/16	60 1/16	34 3/16	46 9/16	11/16	46 5/16	1 3/16	213T	424
300	42 1/2	54 1/2	46 1/2	24 3/16	63 11/16	37 1/8	52	11/16	50 1/2	1 7/16	213T	511
330	46 11/16	59 15/16	50 3/4	25 11/16	67 3/8	40 1/8	57 7/16	11/16	54 3/4	1 7/16	215T	651

ALL DIMENSIONS IN INCHES. WEIGHTS IN LBS., LESS MOTOR.