

This installation manual provides information for installing and configuring the Loren Cook Company constant pressure control system. The system requires a Loren Cook Company fan with an Electronically Commutated, EC, motor with external speed control capability. The manual does not cover any other installation details or applications.



Carefully read this publication and any supplemental documents prior to any installation or maintenance procedure.

For additional safety information, refer to AMCA publication 410-96, *Safety Practices for Users and Installers of Industrial and Commercial Fans*. This document and all Cook publications may be obtained from Cook by phoning (417) 869-6474, extension 166; by FAX at (417) 832-9431; or by e-mail at info@LorenCook.com. All Cook publications are available on LorenCook.com.

For information and instructions on special equipment, contact Cook at (417) 869-6474.

Receiving and Inspection

Carefully inspect the constant pressure control system and accessories for any damage and shortage immediately upon receipt of the unit.

Storage

If the constant pressure control system is stored for any length of time prior to installation store the unit in its original crate and protect it from dust, debris and the weather.

Installation

Pressure Tap

The pressure tap is intended to be located in the duct of the system you want to control. The location is to be determined by the Engineer that designs the system. Loren Cook recommends that the tap be located at least 1/3 of the distance from the bottom of the duct.

The pressure tap is mounted per the instructions included in its packaging.

Control Box

The control box should be mounted vertically in a location that is accessible for operating and configuring the controller. The control box is provided in a NEMA-3R configuration that would allow you to mount it in an outdoor location. The control box should be located within 100 feet of the fan.

To ensure good response time of the pressure transducer, the control box should be located within approximately 50 feet of the pressure tap. If it is not feasible to locate the control box within 50 feet of the tap, it may be necessary to relocate the pressure transducer from within the control box to a location closer to the pressure tap. It will be necessary

to run the wires from the new pressure transducer location to the control box as required. The transducer should be located within 100 feet of the control box.

Connect the pressure transducer, either in the control box or remote mounted, to the pressure tap located in the system duct using 1/4 inch tubing. Depending on whether the duct is operating under a *vacuum* or is *pressurized*, the tube from the pressure tap will be connected differently.

- **Vacuum:**

Connect the tubing to the low connector on the pressure transducer and leave the high connector open to the atmosphere. If the control box is not located in a location that will represent the control pressure, it may be necessary to use a second pressure tap and connect the high connector to the second tap located in the control location.

- **Pressurized:**

Connect the tubing to the high connector on the pressure transducer and leave the low connector open to the atmosphere. If the control box is not located in a location that will represent the control pressure, it may be necessary to use a second pressure tap and connect the low connector to the second tap located in the control location.

Wiring

See page 2 for the wiring diagram.

Connect the 115 volt power to the disconnect switch, by others, and then connect the disconnect switch to both the motor AC power leads and the input connections for the control box per the wiring diagram.

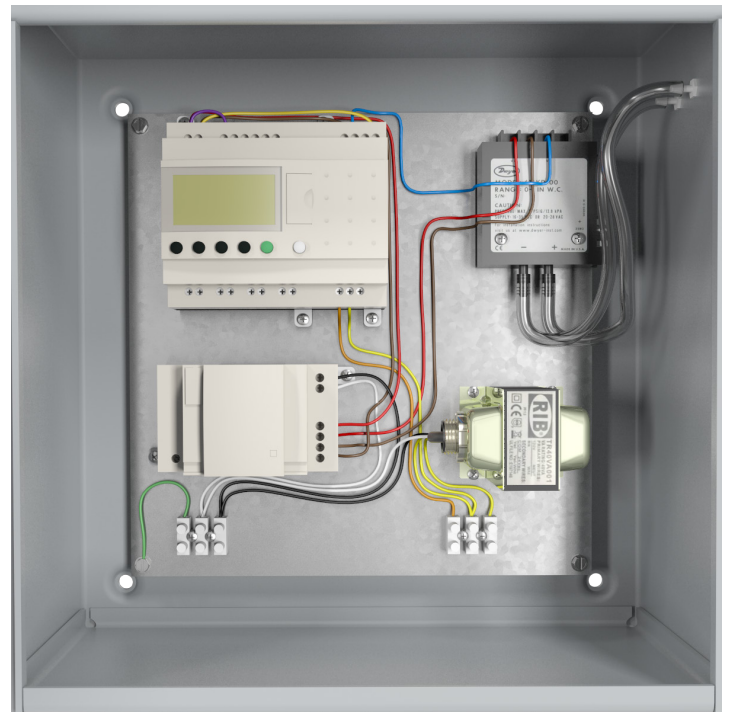

Connect the low voltage input wires from the EC motor to the output connections for the control box per the wiring diagram.

⚠ CAUTION

Electrical Interferences Hazard:

Low-voltage control wires and high-voltage power wires must be installed in separate conduit from control box to the EC motor.

Failure to follow these instructions could result in malfunction or damage.

Operation

The controller is shown below. It has an LCD screen that gives feedback as to the actual pressure reading, pressure set point, motor operating percent, and status. It also has six buttons that change the set point as well as give access to other controller functions.

RealT=0.00 Motor%
 SetPt=0.00 +020
 Status = Normal

Wiring Diagram

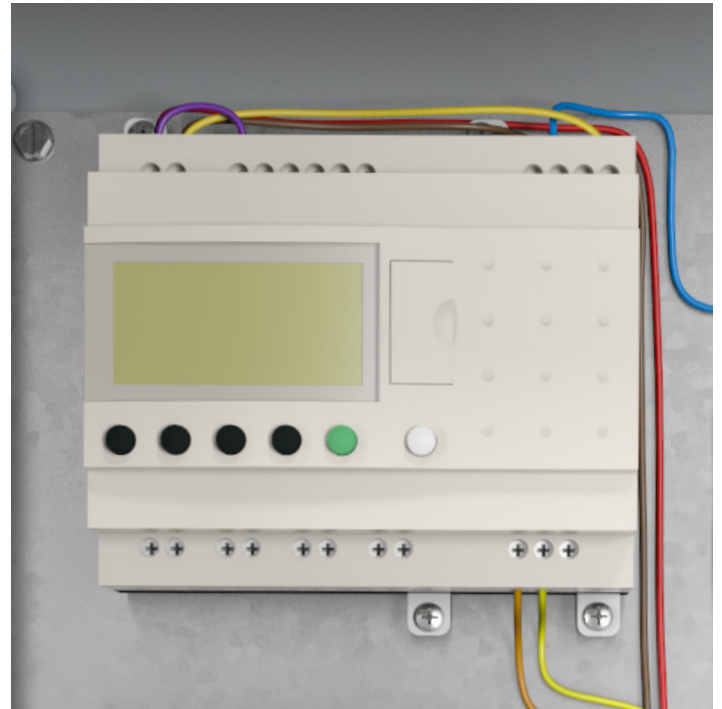
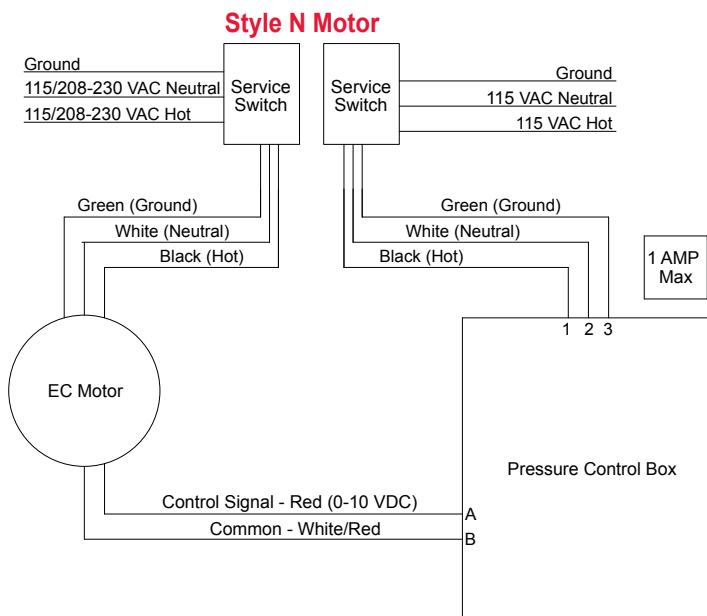
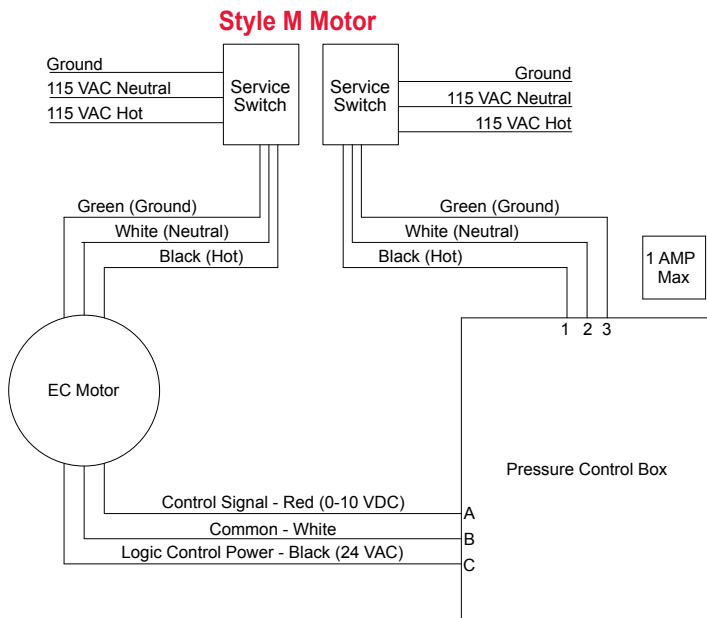

The controller comes pre-programmed from the factory. At initial power-up, the controller initiates and the target pressure will be set at 0.00" w.g. and the display will show the main screen as shown below.

Real Time Pressure

The actual real time pressure reading is displayed in the field labeled *RealT* and is given in inches of water gage.

Motor Output Percentage

The current motor output percentage is displayed under the field labeled *Motor%*. This is the measure of the motor speed that is currently being called for by the controller. The value varies from 20 to 100 percent. The motor will shut down when the value called for drops below 20 percent.

Vari-Flow EC Motors have an internal speed control. The internal speed control acts differently for motor types M and N. If your motor has a user interface with an LED readout, you have a type N motor, otherwise, you have a type M motor. The Custom Pressure Control System modulates the motor speed between the minimum and maximum settings.

For type M motors, the maximum speed is set by adjusting the on-board speed control fully clockwise, and the Custom Pressure Control System will modulate over the range established by the on-board speed control. For type N motors, the on-board speed control must be turned fully counterclockwise in order to accept an external signal. The Custom Pressure Control System will then modulate the fan speed over the entire range between the minimum and maximum programmed speeds. If you do not turn the on-board speed control fully counterclockwise, the motor may not react as expected.

Set Point

The current set point value is displayed in the field labeled SetPt and is given in inches of water gage.

The set point can be changed using the third and fourth buttons from the left edge of the controller. The button with the “▲” symbol below it will increase the set point value and the button with the “▶” symbol will decrease the set point value.

Status

The display will also give the user feedback as to what state the controller is operating.

- **Normal:**
If the pressure is within the acceptable range of the set point and the motor speed is stabilized, the status will be given as Normal.
- **Maximum:**
If the controller is calling for more fan output but the motor is at the maximum rpm, the status will be given as Max.
- **Minimum:**
If the controller is calling for less fan output but the motor is at the minimum rpm, the status will be given as Min.

Hour Meter

During normal operating mode, push the button with the “◀” symbol below it and the display will give a read out of the number of hours that controller has been operating.

Troubleshooting

PROBLEM AND POTENTIAL CAUSE
<p>Fan runs at constant speed. Status = max.</p> <ul style="list-style-type: none"> • Check internal speed controller on motor. Style M motor should be adjusted to maximum speed setting. • Check system compared to design. • Check wiring to EC motor (refer to wiring diagram for proper connections).
<p>Fan runs at constant speed. Status = min.</p> <ul style="list-style-type: none"> • Check internal speed controller on motor. Style N motor should be adjusted to minimum speed setting. • Check system compared to design. • Check wiring to EC motor (refer to wiring diagram for proper connections).
<p>Controller reads RealT=0.00 during operation</p> <ul style="list-style-type: none"> • Check for proper plumbing of pressure transducer (Refer to page 1). • Check tubing from pressure transducer to pressure tap for leaks or cracks. • Check for pressure transducer malfunction. • Check that one of the lines from the pressure transducer is open to the atmosphere.
<p>Controller reads FTL-MOTOR OUT 0%</p> <ul style="list-style-type: none"> • Check for proper plumbing of pressure transducer (Refer to page 1). • Check for blockages at the pressure tap. • Check for blockages in the tubing.
<p>Fan cycles on and off repeatedly</p> <ul style="list-style-type: none"> • Increase set point on controller. • Check system for blockages.

Limited Warranty

Loren Cook Company warrants that your Loren Cook fan was manufactured free of defects in materials and workmanship, to the extent stated herein. For a period of one (1) year after date of shipment, we will replace any parts found to be defective without charge, except for shipping costs which will be paid by you.

This warranty is granted only to the original purchaser placing the fan in service.

This warranty is void if the fan or any part thereof has been altered or modified from its original design or has been abused, misused, damaged or is in worn condition or if the fan has been used other than for the uses described in the company manual. This warranty does not cover defects resulting from normal wear and tear.

To make a warranty claim, notify Loren Cook Company, General Offices, 2015 East Dale Street, Springfield, Missouri 65803-4637, explaining in writing, in detail, your complaint and referring to the specific model and serial numbers of your fan. Upon receipt by Loren Cook Company of your written complaint, you will be notified, within thirty (30) days of our receipt of your complaint, in writing, as to the manner in which your claim will be handled. If you are entitled to warranty relief, a warranty adjustment will be completed within sixty (60) business days of the receipt of your written complaint by Loren Cook Company.

This warranty gives only the original purchaser placing the fan in service specifically the right. You may have other legal rights which vary from state to state.

For fans provided with motors, the motor manufacturer warrants motors for a designated period stated in the manufacturer's warranty. Warranty periods vary from manufacturer to manufacturer. Should motors furnished by Loren Cook Company prove defective during the designated period, they should be returned to the nearest authorized motor service station. Loren Cook Company will not be responsible for any removal or installation costs.



LOREN COOK COMPANY

Corporate Offices 2015 E. Dale Street Springfield, MO 65803

Phone 417-869-6474 Fax 417-862-3820 LorenCook.com